

Description

Where an actively flowing watercourse must be crossed regularly by construction vehicles, a temporary crossing should be provided. Three primary methods are available:

- Culvert crossing
- Stream ford
- Temporary bridge

Culvert crossings and fords are the most commonly used methods. Due to the expense associated with a temporary bridge, these are used primarily on long-term projects.



Photograph TSC-1. A temporary stream crossing using culverts. Photo courtesy of Tom Gore.

Appropriate Uses

Construction vehicles shall be kept out of waterways to the maximum extent practicable. Use a temporary stream crossing when it is absolutely necessary to cross a stream on a construction site. Construct a temporary crossing even if the stream or drainageway is typically dry. Multiple stream crossings should be avoided to minimize environmental impacts.

A permit is required for placement of fill in a waterway under Section 404 of the Clean Water Act. The local office of the U.S. Army Corps of Engineers (USACE) should be contacted concerning the requirements for obtaining a 404 permit. In addition, a permit from the U.S. Fish and Wildlife Service (USFWS) may be needed if endangered species are of concern in the work area. Typically, the USFWS issues are addressed by a 404 permit, if one is required. The municipality of jurisdiction should also be consulted, and can provide assistance. Other permits to be obtained may include a floodplain development permit from the local jurisdiction.

Design and Installation

Design details are provided for these types of stream crossings:

TSC-1. Culvert Crossing

TSC-2. Ford Crossing

TSC-3. Flume Crossing

Temporary Stream Crossing	
Functions	
Erosion Control	Yes
Sediment Control	Yes
Site/Material Management	No

A culvert crossing should be designed to pass at least the 2-year design flow. Use Figure DC-2 from the Temporary Channel Diversion Fact Sheet to determine the 2-year peak flow rate. Culvert sizing must account for the headwater and tailwater controls to properly size the culvert. For additional discussion on design of box culverts and pipes, see the *Major Drainage* chapter in Volume 1. The designer also needs to confirm that the riprap selected is appropriate for the conditions in the channel being crossed.

When a ford must be used, namely when a culvert is not practical or the best solution, the ford should be lined with at least a 12-inch thick layer of Type VL ($D_{50} = 6$ inches) or Type L ($D_{50} = 9$ inches) riprap with void spaces filled with 1-1/2 inch diameter rock. Ford crossings are recommended primarily for crossings of ephemeral (i.e. intermittently, briefly flowing) streams.

For a temporary bridge crossing, consult with a structural and/or geotechnical engineer for temporary bridge design or consider pre-fabricated alternatives.

Maintenance and Removal

Inspect stream for bank erosion and in-stream degradation. If bank erosion is occurring, stabilize banks using erosion control practices such as erosion control blankets. If in-stream degradation is occurring, armor the culvert outlet(s) with riprap to dissipate energy (see Outlet Protection Fact Sheet). If sediment is accumulating upstream of the crossing, remove excess sediment as needed to maintain the functionality of the crossing.

Remove the temporary crossing when it is no longer needed for construction. Take care to minimize the amount of sediment lost into the stream upon removal. Once the crossing has been removed, stabilize the stream banks with seed and erosion control blankets.

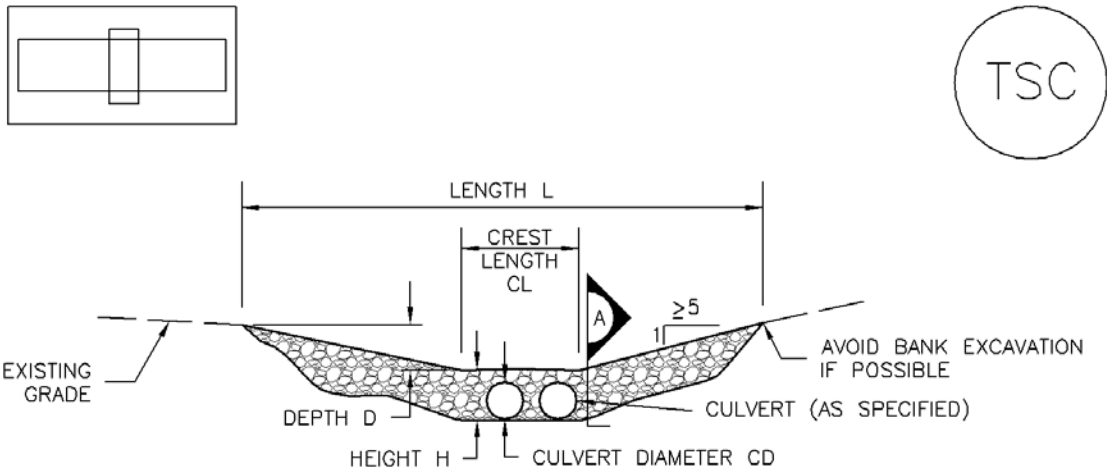

CULVERT CROSSING SECTION

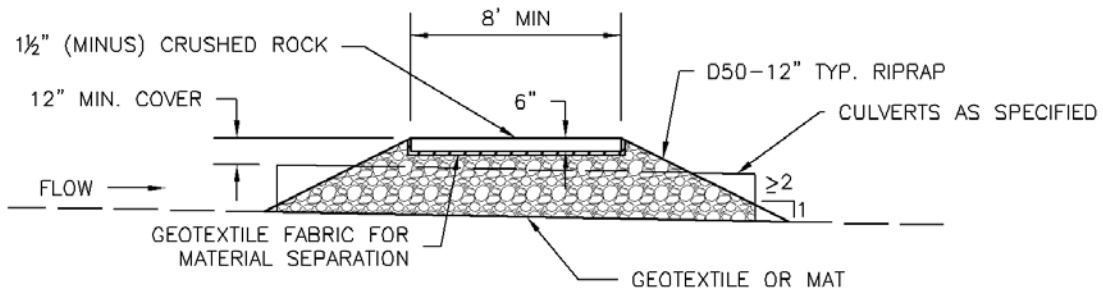

SECTION A

TSC-1. CULVERT CROSSING

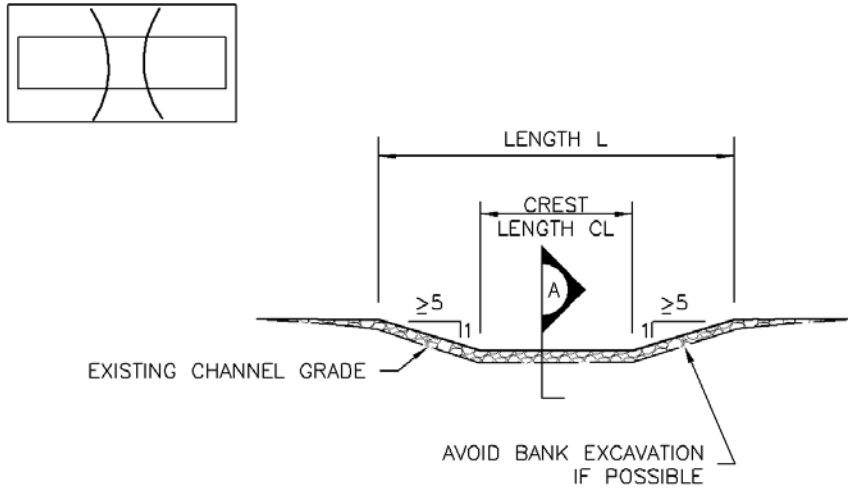

FORD CROSSING SECTION

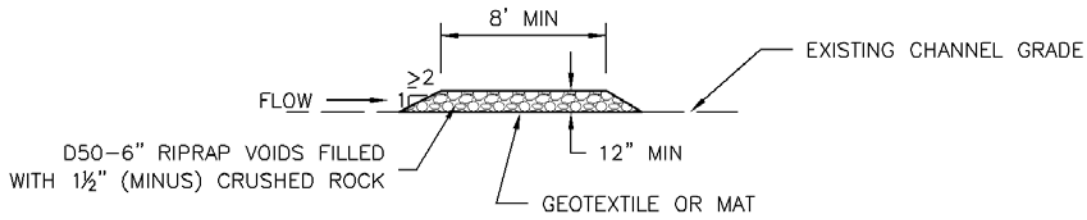

SECTION A

TSC-2. FORD CROSSING

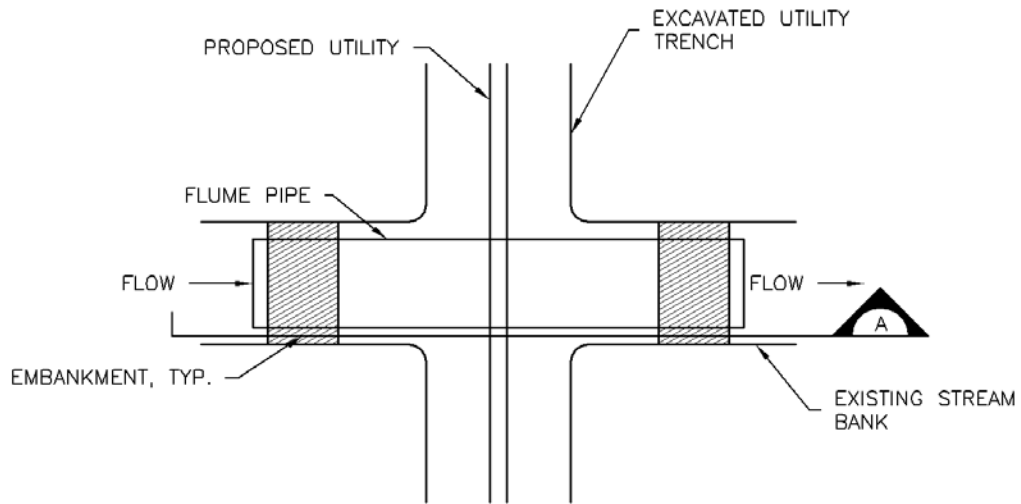
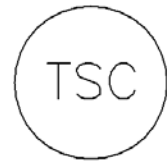

FLUME CROSSING PLAN

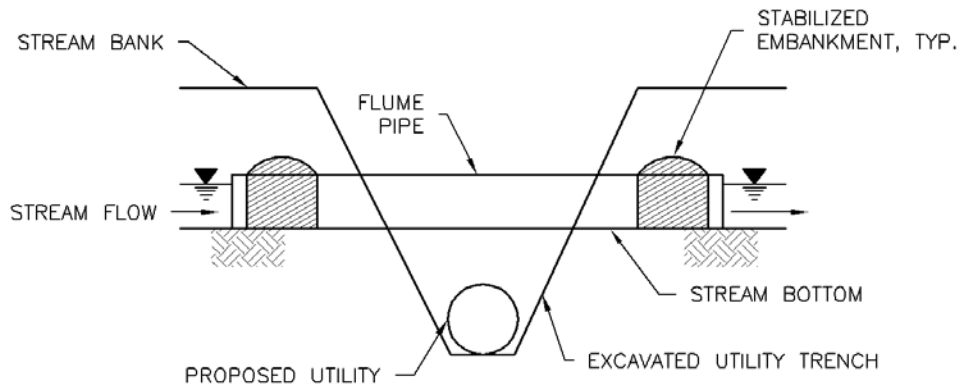

SECTION A

TSC-3. FLUME CROSSING

TEMPORARY STREAM CROSSING INSTALLATION NOTES

1. SEE PLAN VIEW FOR:
 - LOCATIONS OF TEMPORARY STREAM CROSSINGS.
 - STREAM CROSSING TYPE (FORD, CULVERT, OR FLUME).
 - FOR FORD CROSSING: LENGTH (L), CREST LENGTH (CL), AND DEPTH (D).
 - FOR CULVERT CROSSING: LENGTH (L), CREST LENGTH (CL), CROSSING HEIGHT (H), DEPTH (D), CULVERT DIAMETER (CD), AND NUMBER, TYPE AND CLASS OR GAUGE OF CULVERTS.
2. TEMPORARY STREAM CROSSING DIMENSIONS, D50, AND NUMBER OF CULVERTS INDICATED (FOR CULVERT CROSSING) SHALL BE CONSIDERED MINIMUM DIMENSIONS; ENGINEER MAY ELECT TO INSTALL LARGER FACILITIES. ANY DAMAGE TO STREAM CROSSING OR EXISTING STREAM CHANNEL DURING BASEFLOW OR FLOOD EVENTS SHALL BE PROMPTLY REPAIRED.
3. SEE MAJOR DRAINAGE CHAPTER FOR RIPRAP GRADATIONS.
4. WHERE FAILURE OF A STREAM CROSSING CAN RESULT IN SIGNIFICANT DAMAGE OR HARM IT MUST BE DESIGNED BY A STRUCTURAL ENGINEER.

TEMPORARY STREAM CROSSING MAINTENANCE NOTES

1. INSPECT BMPs EACH WORKDAY, AND MAINTAIN THEM IN EFFECTIVE OPERATING CONDITION. MAINTENANCE OF BMPs SHOULD BE PROACTIVE, NOT REACTIVE. INSPECT BMPs AS SOON AS POSSIBLE (AND ALWAYS WITHIN 24 HOURS) FOLLOWING A STORM THAT CAUSES SURFACE EROSION, AND PERFORM NECESSARY MAINTENANCE.
2. FREQUENT OBSERVATIONS AND MAINTENANCE ARE NECESSARY TO MAINTAIN BMPs IN EFFECTIVE OPERATING CONDITION. INSPECTIONS AND CORRECTIVE MEASURES SHOULD BE DOCUMENTED THOROUGHLY.
3. WHERE BMPs HAVE FAILED, REPAIR OR REPLACEMENT SHOULD BE INITIATED UPON DISCOVERY OF THE FAILURE.
4. REMOVE SEDIMENT ACCUMULATED UPSTREAM OF CROSSING AS NEEDED TO MAINTAIN THE FUNCTIONALITY OF THE CROSSING.
5. STREAM CROSSINGS ARE TO REMAIN IN PLACE UNTIL NO LONGER NEEDED AND SHALL BE REMOVED PRIOR TO THE END OF CONSTRUCTION.
6. WHEN STREAM CROSSINGS ARE REMOVED, THE DISTURBED AREA SHALL BE COVERED WITH TOPSOIL, SEEDED AND MULCHED AND COVERED WITH GEOTEXTILE OR OTHERWISE STABILIZED IN A MANNER APPROVED BY THE LOCAL JURISDICTION.

NOTE: MANY JURISDICTIONS HAVE BMP DETAILS THAT VARY FROM UDFCD STANDARD DETAILS. CONSULT WITH LOCAL JURISDICTIONS AS TO WHICH DETAIL SHOULD BE USED WHEN DIFFERENCES ARE NOTED.

(DETAIL ADAPTED FROM DOUGLAS COUNTY, COLORADO AND CITY OF AURORA, COLORADO (Vg. DSWC), NOT AVAILABLE IN AUTOCAD)