

Description

This section provides guidance and details for outlet structures for use primarily with BMPs utilizing sedimentation, (i.e., extended detention basins (EDBs), retention ponds, and constructed wetland ponds). The information provided in this section includes guidance for different size watersheds as well as for incorporating Full Spectrum Detention as described in the *Storage* chapter of Volume 2.

The details contained in this Fact Sheet are intended to provide a starting point for design. UDFCD recommends that design details for outlet structures be specific for each site with structural details drawn to scale. The details provided in this Fact Sheet are not intended to be used without modification or additional detail.



Photograph OS-1. Although each site is different, most sedimentation BMPs have similar outlet structures. Each structure should include a partially submerged orifice plate with a screen (or grate) protecting the orifice plate from clogging, and an overflow weir for flows exceeding the WQCV or excess urban runoff volume (EURV), when full spectrum detention is used.

Outlet Design

Large Watershed Considerations

UDFCD recommends that water quality treatment be provided close to the pollutant source. This is a fundamental concept of Low Impact Development (LID). Although flood control facilities, including Full Spectrum Detention facilities, have been shown to be very effective for watersheds exceeding one square mile, this is not the case for water quality facilities. One reason for this is that the baseflow associated with a larger watershed will vary and can be difficult to estimate. The orifice plate should be designed to pass the baseflow while detaining the water quality capture volume (WQCV) for approximately 40 hours. When the baseflow is overestimated, the WQCV is not detained for the recommended time, passing through without treatment. When the baseflow is underestimated, the elevation of the permanent pool will be higher than designed, causing maintenance issues as well as reducing the volume available for detention of the WQCV, which also allows for a portion of this volume to pass through without treatment. For this reason, UDFCD recommends that facilities designed for both water quality and flood control be limited, where possible, to watersheds without a baseflow. The maximum recommended watershed for combined facilities is one square mile. Additional discussion on designing for baseflows is provided in the EDB BMP Fact Sheet (T-5).

Designing for Maintenance

Rather than using the minimum criteria, consider maximizing the width of the trash rack to the geometry of the outlet. This will reduce clogging and frequency of maintenance. Reduced clogging in EDB outlet structures will preserve the initial surcharge volume thus reducing frequency of inundation in the bottom of the basin. This will benefit the grasses and reduce long-term EDB maintenance requirements (including sediment removal in the grassed area) and may reduce the life-cycle cost of the BMP.

Orifice Plates and Trash Racks

An orifice plate is used to release the WQCV slowly over 40 hours. For Full Spectrum Detention, the orifice plate is extended to drain a larger volume, the EURV, over approximately 72 hours. The figures and tables in this section provide recommendations for orifice configurations and trash rack type and size. Guidance is provided for plates using both circular and rectangular orifices.

Orifice Sizing

Follow the design steps included in the BMP Fact Sheet for the appropriate BMP. The UD-BMP workbook, available at www.udfcd.org, can also be used to calculate the required orifice area per row. This is the first step in detailing the outlet structure for sedimentation BMPs. It is good practice to maximize the area of each orifice to avoid clogging. The *UD-BMP* workbook will allow up to two columns of circular orifices before recommending a single rectangular orifice. A rectangular orifice is recommended when the required open area per row is equal to approximately 4 square inches or greater. Details showing orifice configurations are provided in Figure OS-4. Table OS-1 can be used to determine orifice shape and number of columns based on the required area per row.

Trash Rack Sizing

Once the size of the orifice has been determined, this information, along with the total orifice area in the water quality plate, is used to determine the total open area of the grate (see Figure OS-1). The trash rack should be sized using this figure. This Fact Sheet also includes standard tables that can be used when the outlet is designed per UDFCD criteria, including inundation of trash rack into the permanent pool for a depth of approximately 2.5 feet. The standard tables assume the use of the specified stainless steel screen with circular orifices and the specified aluminum bar grate for use with rectangular orifices. Use Figure OS-1 when using a different trash rack material or when the geometry of the structure does not fit within the assumptions of the tables. Use Tables OS-2a and OS-2b for circular orifices and Tables OS-3a and OS-3b for rectangular orifices. Be aware, these tables provide the minimum width clear for the trash rack frame. It is also important to provide adequate width for attachment to the outlet structure (see Photos OS-2 and OS-3). Also, consider maximizing the width of the trash rack to the geometry of the outlet. This will reduce clogging and maintenance requirements associated with cleaning the trash rack.



Photograph OS-2. This trash rack could not be properly attached due to its inadequate flange width.



Photograph OS-3. Trash rack after repair.

Table OS-1. Orifice Sizing

Hole Dia. (in) ¹	Hole Dia. (in)	Area per Row (in ²)	
		n = 1	n = 2
1/4	0.250	0.05	-
5/16	0.313	0.08	-
3/8	0.375	0.11	-
7/16	0.438	0.15	-
1/2	0.500	0.2	-
9/16	0.563	0.25	-
5/8	0.625	0.31	-
11/16	0.688	0.37	-
3/4	0.750	0.44	-
13/16	0.813	0.52	-
7/8	0.875	0.6	-
15/16	0.938	0.69	-
1	1.000	0.79	-
1-1/16	1.063	0.89	-
1-1/8	1.125	0.99	-
1-3/16	1.188	1.11	-
1-1/4	1.250	1.23	-
1-5/16	1.313	1.35	-
1-3/8	1.375	1.48	-
1-7/16	1.438	1.62	3.24
1-1/2	1.500	1.77	3.54
1-9/16	1.563	1.92	3.84
1-5/8	1.625	2.07	-
1-11/16	1.688	2.24	-
1-3/4	1.750	2.41	-
1-13/16	1.813	2.58	-
1-7/8	1.875	2.76	-
1-15/16	1.938	2.95	-
2	2.000	3.14	-
n = Number of Columns of Orifices			
Steel Thickness (Min.)		1/4"	5/16"
¹ If desired, interpolate to the nearest 32" to better match the needed area.			

Use one column of rectangular orifices when the needed area exceeds 3.84 in²

Rectangular Height (in) = 2

Rectangular Width (in) = Required Area / 2 in

Rectangular Width (in)	Steel Thickness (in)
≤6	≥1/4
≤8	≥5/16
≤10	≥3/8
>10	≥1/2

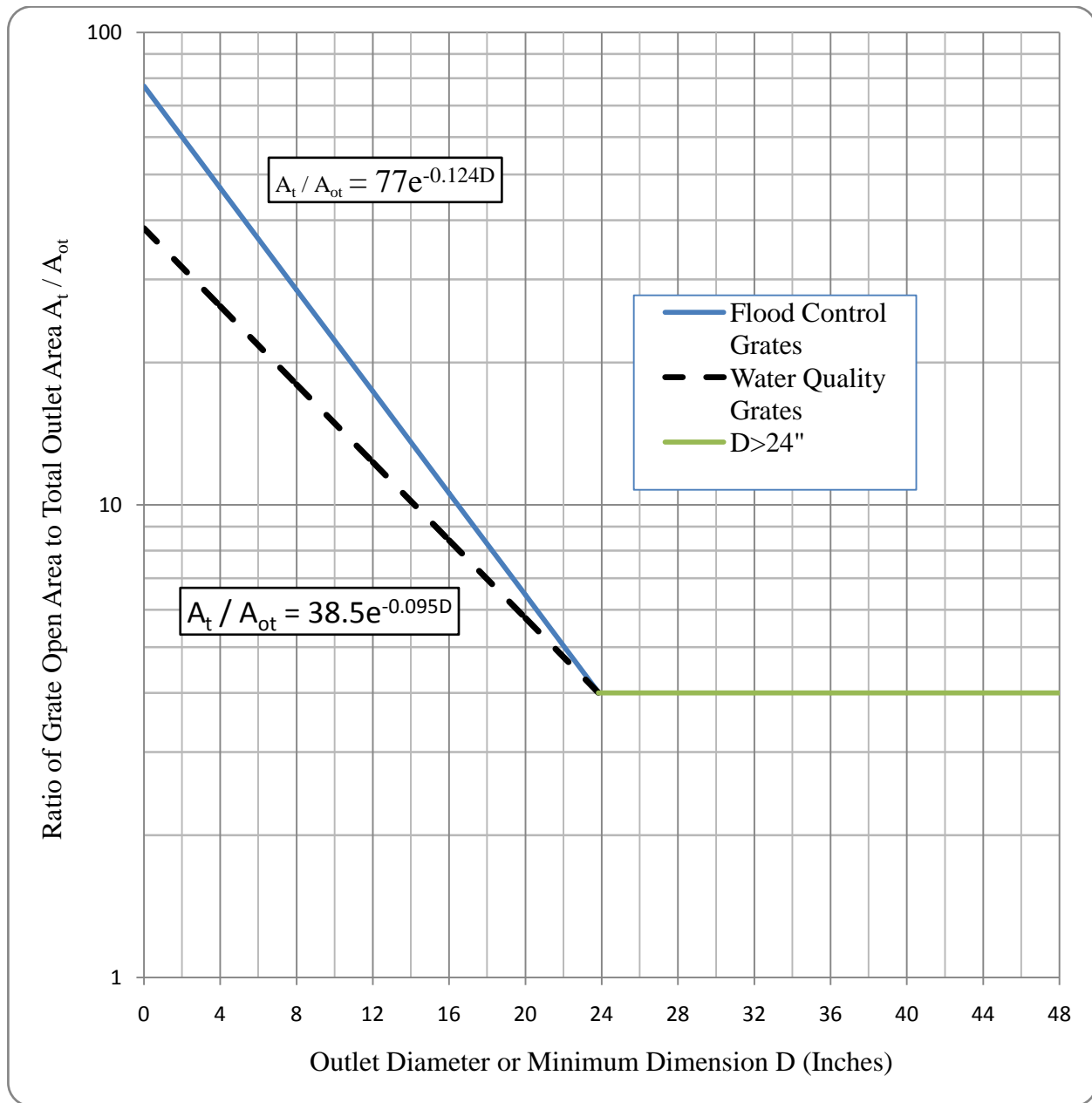

Figure OS-1. Trash Rack Sizing

Table OS-2a. Trash Rack Sizing for Circular Orifices^{1,3}

Number of Columns	Diameter of Circular Orifice (in)	Width of Trash Rack Opening ($W_{opening}$) as a Function of Water Depth H Above Lowest Perforation				
		H=2.0'	H=3.0'	H=4.0'	H=5.0'	H=6.0'
1	≤ 1-1/4	12" ²	12" ²	12" ²	12"	13"
1	≤ 1-1/2	12" ²	14"	16"	17"	18"
1	≤ 1-3/4	15"	18"	21"	22"	24"
1	≤ 2	19"	23"	26"	28"	30"
2	1-7/16	21"	26"	29"	31"	33"
2	1-1/2	23"	28"	31"	34"	35"
2	1-9/16	24"	30"	34"	36"	38"

¹ For use with Johnson VEE Wire™ Stainless Steel Screen1 (or equivalent screen with 60% open area). Assumes inundation of well screen into the permanent pool 2'4".

² Represents the minimum recommended width of 12 inches, otherwise width is calculated based on Figure OS-1.

³ This table provides the minimum opening in the concrete, not the minimum width of the well screen. Ensure the well screen is wide enough to properly attach to the structure.

Table OS-2b. Trash Rack Specifications for Circular Orifice Plates

Max. Width of Trash Rack Opening (in)	Screen #93 VEE Wire Slot Opening (in)	Support Rod Type	Support Rod, On Center, Spacing	Total Screen Thickness	Carbon Steel Frame Type
≤9	0.139	#156 VEE	¾"	0.31"	¾"x1.0" flat bar
≤18	0.139	TE 0.074"x0.50"	1"	0.655"	¾" x 1.0 angle
≤24	0.139	TE 0.074"x0.75"	1"	1.03"	1.0" x 1½" angle
≤27	0.139	TE 0.074"x0.75"	1"	1.03"	1.0" x 1½" angle
≤30	0.139	TE 0.074"x1.0"	1"	1.155"	1 ¼"x 1½" angle
≤36	0.139	TE 0.074"x1.0"	1"	1.155"	1 ¼"x 1½" angle
≤42	0.139	TE 0.105"x1.0"	1"	1.155"	1 ¼"x 1½" angle

¹ Johnson Screens, St. Paul, Minnesota, USA (1-800-833-9473)

Table OS-3a. Trash Rack Sizing for 2" High Rectangular Orifices

Width (W) of 2" Rectangular Orifice (in)	Minimum Width of Trash Rack Opening ($W_{opening}$) as a Function of Water Depth H Above Lowest Perforation					Spacing of Bearing Bars, Cross Rods
	H≤2.0 ft.	H≤3.0 ft.	H≤4.0 ft.	H≤5.0 ft.	H≤6.0 ft.	
2	1.7'	2.1'	2.4'	2.5'	2.7'	1-3/16", 2"
≤ 2.5	2.2'	2.6'	3'	3.2'	3.4'	1-3/16", 2"
≤ 3.0	2.6'	3.2'	3.5'	3.8'	4.0'	1-3/16", 2"
≤ 3.5	3.0'	3.7'	4.1'	4.5'	4.7'	1-3/16", 2"
≤ 4.0	3.4'	4.2'	4.7'	5.1'	5.4'	1-3/16", 2"
≤ 4.5	3.6'	4.4'	4.9'	5.3'	5.6'	1-3/16", 4"
≤ 5.0	4.0'	4.8'	5.4'	5.9'	6.2'	1-3/16", 4"
≤ 5.5	4.4'	5.3'	6.0'	6.5'	6.8'	1-3/16", 4"
≤ 6.0	4.8'	5.8'	6.5'	7.0'	7.4'	1-3/16", 4"
≤ 6.5	5.2'	6.3'	7.1'	7.6'	8.1'	1-3/16", 4"
≤ 7.0	5.6'	6.8'	7.6'	8.2'	8.7'	1-3/16", 4"
≤ 7.5	6.0'	7.3'	8.2'	8.8'	9.3'	1-3/16", 4"
≤ 8.0	6.4'	7.8'	8.7'	9.4'	9.9'	1-3/16", 4"
≤ 8.5	6.8'	8.2'	9.2'	10'	*	1-3/16", 4"
≤ 9.0	7.2'	8.7'	9.8'	*	*	1-3/16", 4"
≤ 9.5	7.6'	9.2'	*	*	*	1-3/16", 4"
≤ 10.0	8.0'	9.7'	*	*	*	1-3/16", 4"
≤ 10.5	8.3'	*	*	*	*	1-3/16", 4"
≤ 11.0	8.7'	*	*	*	*	1-3/16", 4"
≤ 11.5	9.1'	*	*	*	*	1-3/16", 4"
≤ 12.0	9.5'	*	*	*	*	1-3/16", 4"

* Size trash rack per Figure OS-1. Use 4-inch high staggered rectangular orifices to limit size of the structure.
Notes:

1. Width shown based on Figure OS-1 assuming inundation of trash rack into the permanent pool 2'4".
2. This table provides the minimum opening in the concrete, not the minimum width of the trash rack.
Ensure the trash rack is wide enough to properly attach to the structure.

Table OS-3b. Trash Rack Specifications for 2" High Rectangular Orifices

Water Depth Above Lowest Opening, H (ft)	Minimum Bearing Bar Size, Bearing Bars Aligned Vertically (in)
2.0'	1" x 3/16"
3.0'	1-1/4" x 3/16"
4.0'	1-3/4" x 3/16"
5.0'	2" x 3/16"
6.0'	2-1/4" x 3/16"

Outlet Geometry

Outlets for small watersheds will typically be sized for maintenance operations while the geometry of outlets for larger watersheds may be determined based on the required size of the trash rack. For all watershed sizes, the outlet should be set back into the embankment of the pond to better allow access to the structure. This also provides a more attractive BMP. For larger watersheds, this will require wing walls. Wing walls are frequently cast-in-place concrete, although other materials, such as grouted boulders, may be used where appropriate. Consider safety, aesthetics, and maintenance when selecting materials and determining the geometry. A safety rail should be included for vertical drops of 3 feet or more. Depending on the location of the structure in relation to pedestrian trails, safety rails may also be required for lesser drops. Stepped grouted boulders can be used to reduce the height of vertical drops.

As shown in Figures EDB-1 and EDB-2 provided in BMP Fact Sheet T-5, wing walls can be flared or parallel. There are advantages to both configurations. Parallel wing walls may be more aesthetic; however, depending on the geometry of the pond, may limit accessibility to the trash rack. Flared wing walls can call attention to the structure but provide better accessibility and sometimes a vertical barrier from the micropool of an EDB, which can increase safety of the structure. Parallel walls can also be used with a second trash rack that is secured flush with the top of the wall as shown in Photo OS-4. This eliminates the need for a safety rail and may provide additional protection from clogging; however, it creates a maintenance issue by restricting access to the water quality screen. The rack shown in Photo OS-4 was modified after construction due to this problem.



Photograph OS-4. Maintenance access to the water quality trash rack was compromised by the location of a secondary trash rack on this outlet. This may have been included as a safety rack or as additional protection from clogging. The owner modified the structure for better access. A safety rail would have been a better solution.



Photograph OS-5. Interruptions in the horizontal members of this trash rack and the spacing of the vertical members allow easier access to clean the water quality grate. A raking tool can be used to scrape the water quality trash rack.

Micropools within the Outlet Structure

The micropool of an EDB may be placed inside the structure when desired. This is becoming increasingly common for smaller watersheds and near airfields where large bird populations can be problematic. When designing this type of structure, consider maintenance of the water quality trash rack. The secondary trash rack should be designed to allow maintenance of the water quality trash rack similar to that shown in Photo OS-5. This concept can easily be incorporated into smaller outlet structures (see Figures OS-7 and OS-8 for details).

Outlet Structure Details

A number of details are presented in this section to assist designers with detailing outlet structures. Table OS-2 provides a list of details available at www.udfcd.org. These details are not intended to be used in construction plans without proper modifications as indicated in Table OS-4.

Table OS-4. Summary of Outlet Structure Details and Use

Figure	Detail	Use of Detail
OS-2	Typical Outlet Structure for Full Spectrum Detention	Conceptual.
OS-3	Typical Outlet Structure for WQCV Treatment and Attenuation	Conceptual.
OS-4	Orifice Plate and Trash Rack	Outlet section. Modify per true structure geometry and concrete reinforcement. Modify notes per actual design.
OS-5	Typical Outlet Structure with Circular Orifice Plate	Outlet sections. Modify per true structure geometry and concrete reinforcement. Add additional sections and detailing as necessary. Modify notes per actual design.
OS-6	Typical Outlet Structure with Rectangular Orifice Plate	Outlet sections. Modify per true structure geometry and concrete reinforcement. Add additional sections and detailing as necessary. Modify notes per actual design.
OS-7	Full Spectrum Detention Outlet Structure for 5-acre Impervious Area or Less	Outlet profile and section. Modify per true EURV elevation and concrete reinforcement. Add additional sections and detailing as necessary.
OS-8	WQCV Outlet Structure for 5-acre Impervious Area or Less	Outlet sections. Modify per true WQCV elevation and concrete reinforcement. Add additional sections and detailing as necessary.

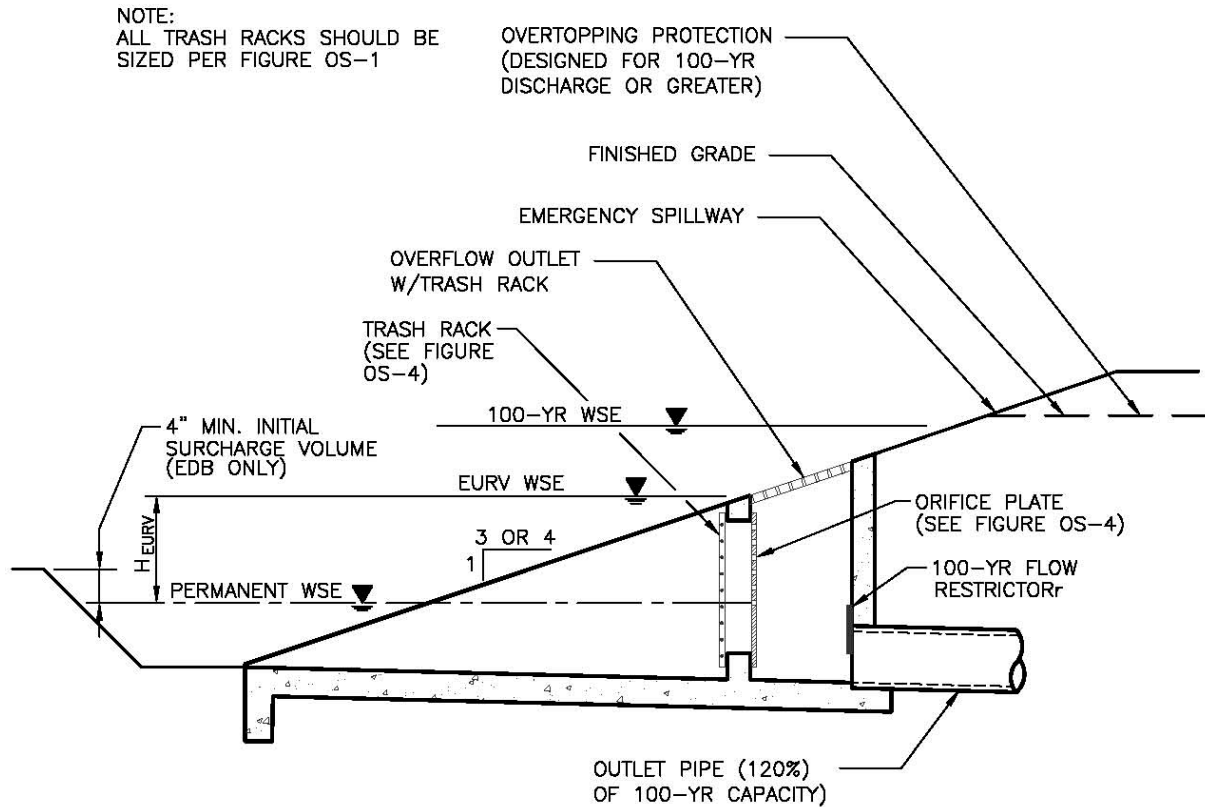

Figure OS-2. Typical Outlet Structure for Full Spectrum Detention

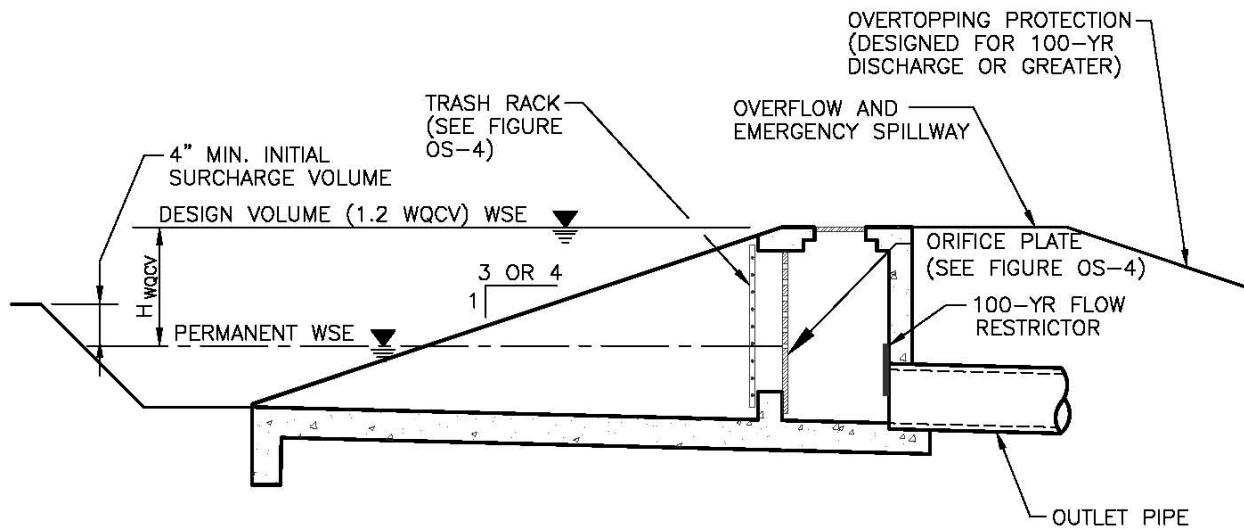
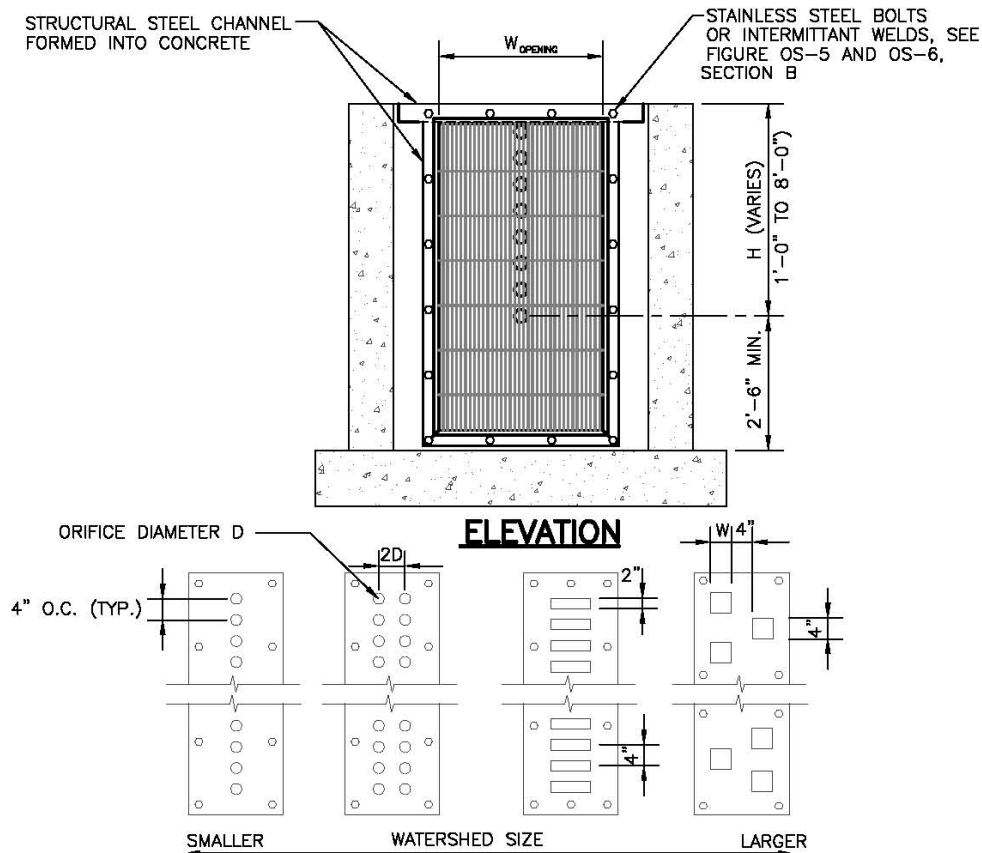

Figure OS-3. Typical Outlet Structure for WQCV Treatment and Attenuation



EXAMPLE ORIFICE PATTERNS

ORIFICE PLATE NOTES:

1. MINIMIZE THE NUMBER OF COLUMNS.
2. PROVIDE GASKET MATERIAL BETWEEN THE ORIFICE PLATE AND CONCRETE.
3. BOLT PLATE TO CONCRETE 12" MAX. ON CENTER.

EURV AND WQCV TRASH RACKS:

1. WELL-SCREEN TRASH RACKS (FOR CIRCULAR ORIFICES) SHALL BE STAINLESS STEEL AND SHALL BE ATTACHED BY INTERMITTENT WELDS ALONG THE EDGE OF THE MOUNTING FRAME.
2. BAR GRATE TRASH RACKS (FOR RECTANGULAR ORIFICES) SHALL BE ALUMINUM AND SHALL BE BOLTED USING STAINLESS STEEL HARDWARE.
3. TRASH RACK WIDTHS PROVIDED IN TABLE OS-2A AND OS-3A ARE FOR SPECIFIED TRASH RACK MATERIAL AND NEED TO BE ADJUSTED FOR MATERIALS HAVING A DIFFERENT OPEN AREA/GROSS AREA RATIO (R VALUE)
4. STRUCTURAL DESIGN OF TRASH RACKS SHALL BE BASED ON FULL HYDROSTATIC HEAD WITH ZERO HEAD DOWNSTREAM OF THE RACK.

OVERFLOW TRASH RACKS:

1. ALL TRASH RACKS SHALL BE MOUNTED USING STAINLESS STEEL HARDWARE AND PROVIDED WITH HINGED AND LOCKABLE OR BOLTABLE ACCESS PANELS.
2. TRASH RACKS SHALL BE STAINLESS STEEL, ALUMINUM, OR STEEL. STEEL TRASH RACKS SHALL BE HOT DIP GALVANIZED AND MAY BE HOT POWDER COATED AFTER GALVANIZING.
3. TRASH RACKS SHALL BE DESIGNED SUCH THAT THE DIAGONAL DIMENSION OF EACH OPENING IS SMALLER THAN THE DIAMETER OF THE OUTLET PIPE.
4. STRUCTURAL DESIGN OF TRASH RACKS SHALL BE BASED ON FULL HYDROSTATIC HEAD WITH ZERO HEAD DOWNSTREAM OF THE RACK.

Figure OS-4. Orifice Plate and Trash Rack

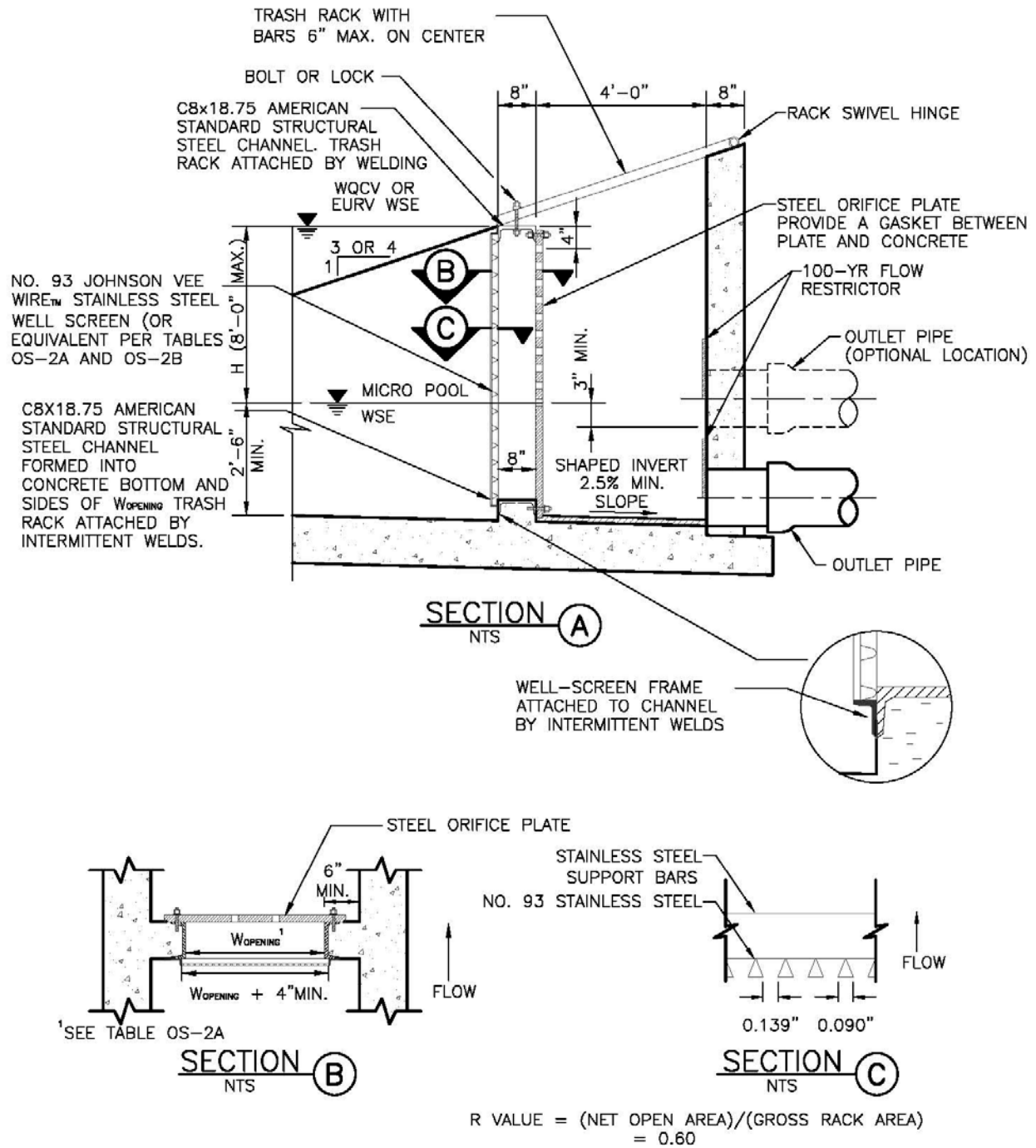

Figure OS-5. Typical Outlet Structure with Circular Orifice Plate

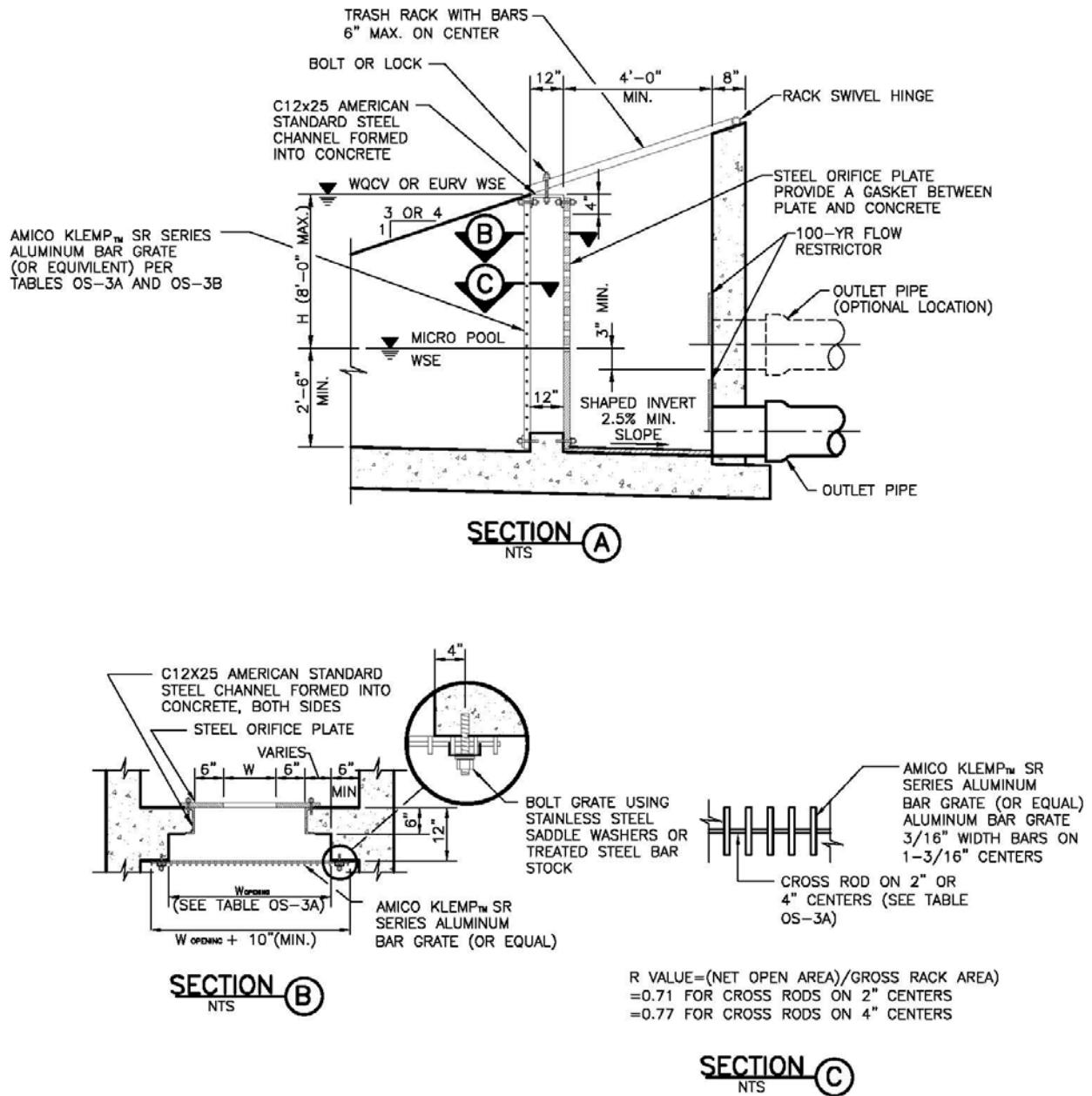

Figure OS-6. Typical Outlet Structure with Rectangular Orifice Plate

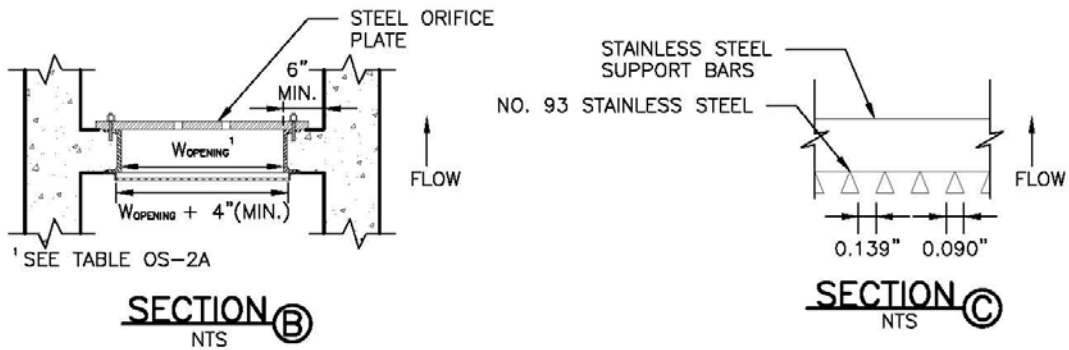
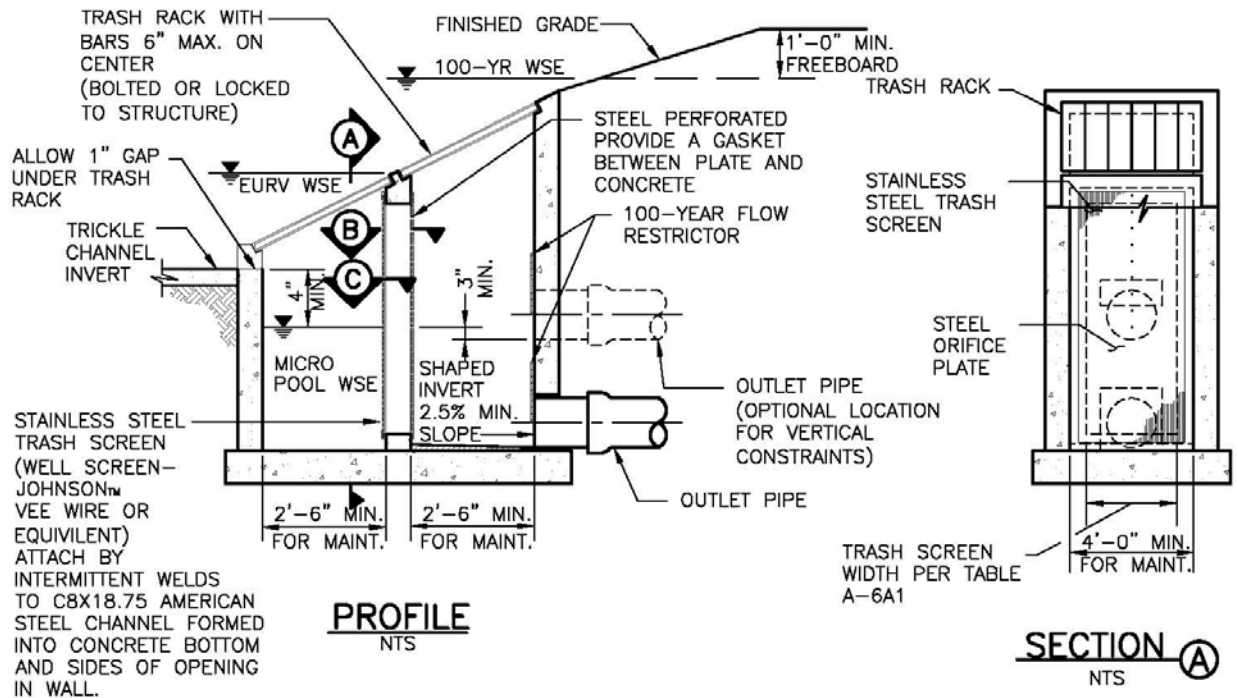

Figure OS-7. Full Spectrum Detention Outlet Structure for 5-acre Impervious Area or Less

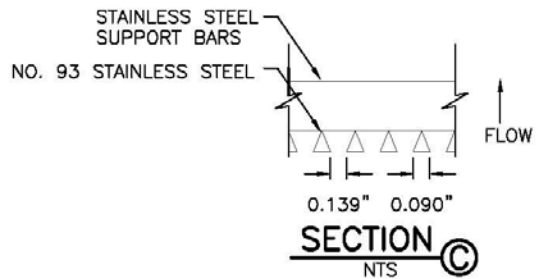
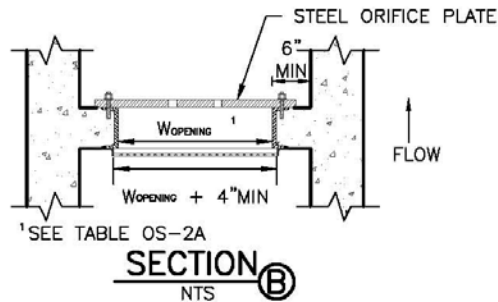
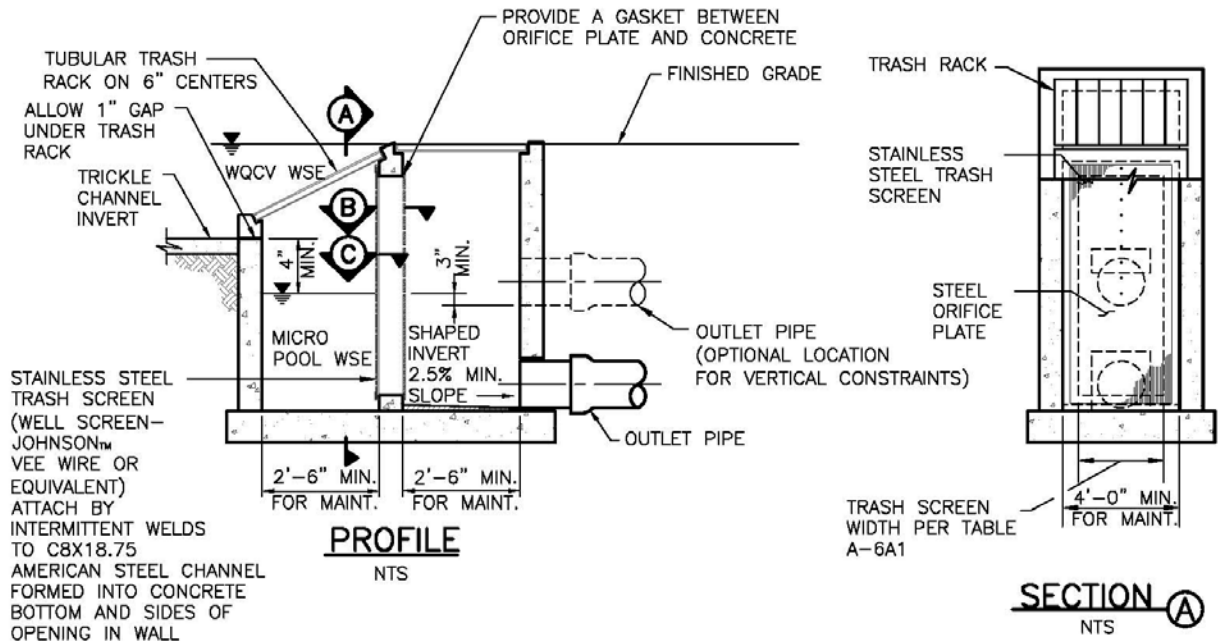

Figure OS-8. WQCV Outlet Structure for 5-acre Impervious Area or Less